

CIPHER L

EN

MANUAL^{UL}

by Yabu Pushelberg

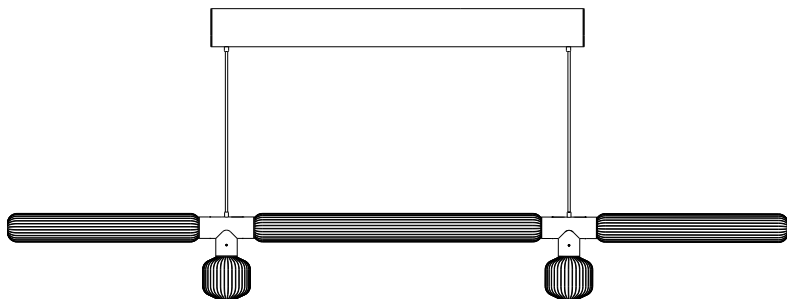

LASVIT

Symbols



Warnings

Warns you of high risk of damage to the fixture or injury.



Warns of electrical injury

Warns you of high risk of injury should a live part be directly or indirectly touched.



Notice

Warns you about possible damage to the fixture.



Important

Important information regarding the usage of your fixture.



Note

Gives you general information about the usage of your fixture.



Class II equipment

Lighting does not require a connection to electrical earth (ground)



For indoor use only

Please read this manual carefully and keep it in case you need assistance while performing maintenance and cleaning procedures.



Never dispose of this product in mixed municipal waste, it must be submitted at the designated disposal collection center.

1. Warnings



Risk of electrical injury

Warns you of high risk of electrical injury should a live part be directly or indirectly touched.

Before starting any procedures make sure that the power to the lighting fixture is switched off and secured against unauthorized, negligent or accidental switching on.



Warnings

Warns you of high risk of damage to the fixture or injury.

Installation and electrical wiring should be carried out by a qualified electrician to prevent any damage to health or property.

This lighting fixture is to be mounted on fire proof surfaces

For indoor use only. Dry location only.

The manufacturer shall not be held liable for any defects caused by unqualified handling of the lighting fixture.

Lasvit shall not be held liable for any injuries or damage to the fixture or other property caused during installation or by improper fixing.

If the power cable of the luminaire is damaged, it shall be replaced by the manufacturer or a similar qualified person only in order to prevent any damage to health or property.

Do not cover the lighting fixture with any material, it is necessary for the hot parts to be cooled by freely flowing air, otherwise there is a risk of fire.

If the light fixture is used in a way other than as described in the manual, it may become hazardous or its lifespan may be shortened.

Never rotate the light when suspended.

Should the cable need to be shortened, ask a qualified technician (licensed electrician) to disconnect the cable, shorten it and reconnect it. The same applies to lengthening the cable, however a new, longer cable needs to be purchased separately. Lasvit shall not be held liable for any injuries or damage to the fixture or other property caused by unauthorised manipulation with the cable or its parts.



Important

Important information regarding the usage of your fixture.

Installation requires 2 people.

Fixing material is not part of the lighting fixture kit.

To retain quality of hand-blown glass, Lasvit recommends to cleaning the glass at least every 3 months, please see Product care manual.

Proper fixing is the responsibility of the customer.

Led module can be supplied by the manufacturer only, Lasvit s.r.o.

Led module can be replaced only by a qualified electrician (trained electrician).

2. Cleaning manual

General Instructions

We recommend regular cleaning to maintain the appearance of the light.

Lights may require additional cleaning due to transportation, storage and installation.

Please follow the recommended instructions when cleaning.

Never rotate the light when it is suspended.

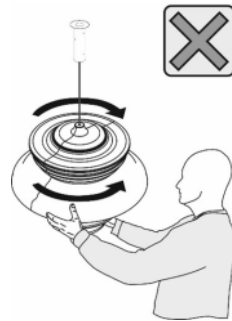

If you need advice or have any questions, please contact us at customer.care@lasvit.com or your sales representative.

Recommended Cleaning Agents:

Use of other than recommended cleaning agents may damage the surface of the light.

Do not use products with an abrasive component.

Do not use products containing alcohol.

Do not use products containing silicone.

Use a dish detergent for standard cleaning.

For rinsing, use clean lukewarm water, ideally demineralized water.

Recommended Cleaning Aids:

The aids must always be clean and free of abrasive parts.

Use a microfiber cloth for cleaning.

Use a soft sponge without abrasive side for washing.

Use an absorbent lint-free cloth for drying.

Use high-quality paper towels for drying and polishing.

Use a dusting wand. We recommend a feather duster with a handle.

Regular Cleaning - No Disassembly

For routine maintenance, carefully dust the surface with a clean, soft duster.

Then polish it with a polishing agent and a clean microfiber cloth.

Thorough Cleaning - Partial Disassembly

Before starting the disassembly, carefully dust the surface with a clean, fine duster.

Prepare two containers, placing a clean towel in the bottom of each to avoid scratching the glass component.

In the first container, prepare a washing solution and wash each glass component.

In the second container, with clean water, rinse the glass component.

Spread the components on a clean, dry towel, let any water drops drain, then dry thoroughly using an absorbent, lint-free cloth.

Repeat this procedure if necessary.

Then polish with a polishing agent and a clean microfiber cloth.

Before reinstalling the components, use cotton gloves to avoid leaving undesirable fingerprints on them.

Cleaning with Service Required

In the case of dirt that cannot be cleaned by the methods described above or that requires extensive disassembly, we recommend contacting the manufacturer or a professional service provider.

3. Step-by-step installation

4. Light setting
5. Canopy disassembly
6. Ceiling preparation
7. Fixing plate installation
8. Cable preparation
9. Electrical connection
10. Canopy mounting
11. Installation of the glass



Consulting a specialist before choosing type of fixing materials and procedures for a given fixture is highly recommended.

Pictures shown are for illustration purposes only.

Package contents:

1x Canopy with cover plate

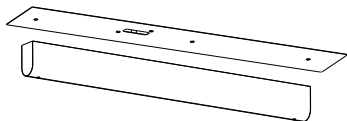

2x Tube body



1x Bag with accessories

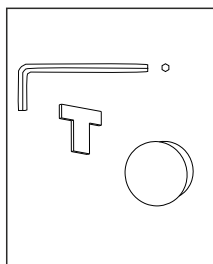

2x Cables



1x Glass L



2x Glass M



2x Glass S



4. Light setting



If you will install the pendant in an area where unwanted reflections from different surfaces (floor, wall, ceiling) may occur, you have to make allowance for light scattering that can produce different light phenomena on the surface.

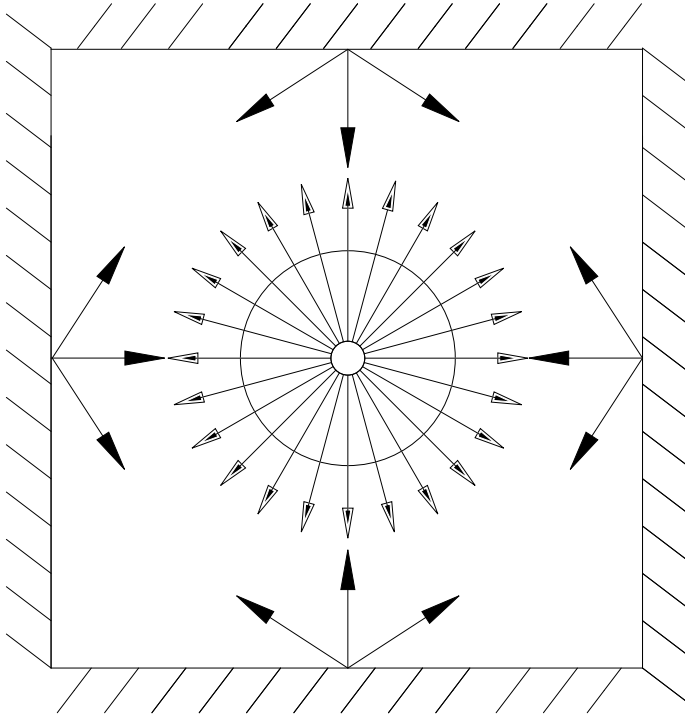

Lasvit recommends not installing the chandelier at the eye level. If situation requires it, use the diffusers that are included in the package. Installation of the diffusers see on.

Diffusers installation

Install the diffusers on all LED modules. For fixation of the diffusers use the double-sides tape.

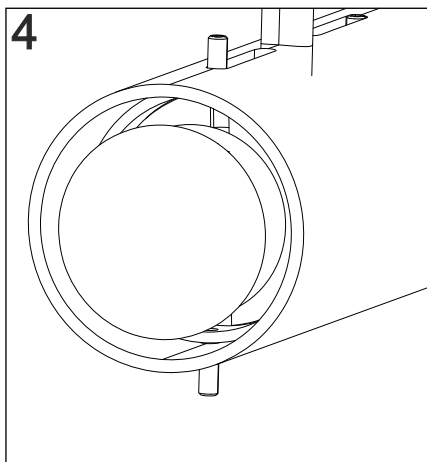
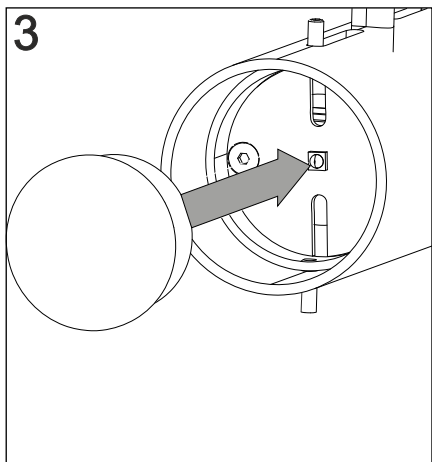
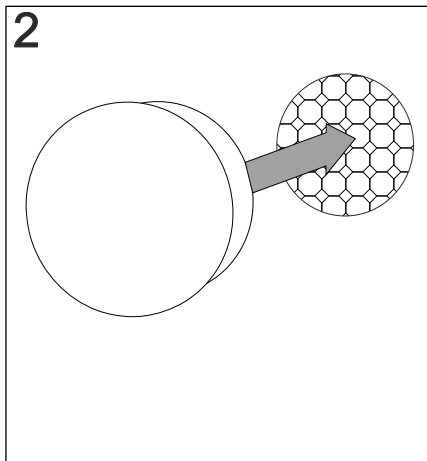
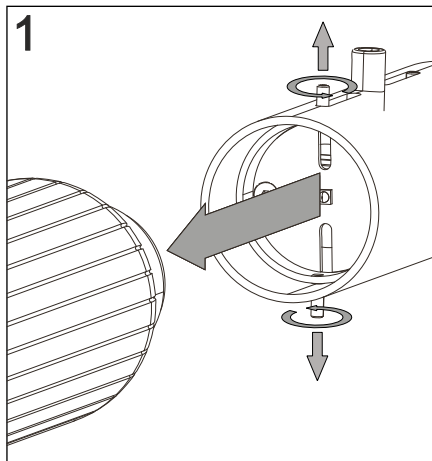

5. Canopy disassembly

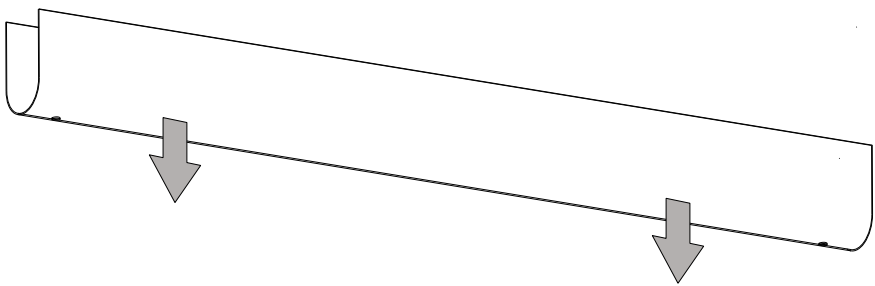
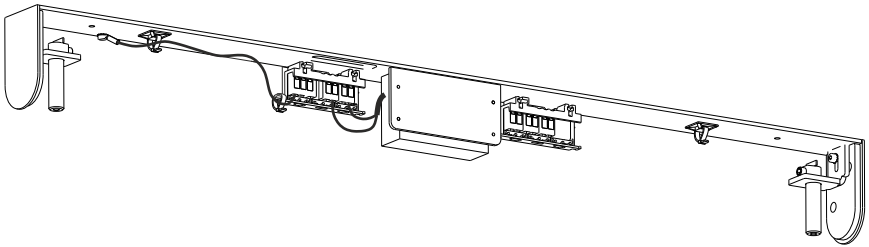

6. Ceiling preparation

Step 6a/

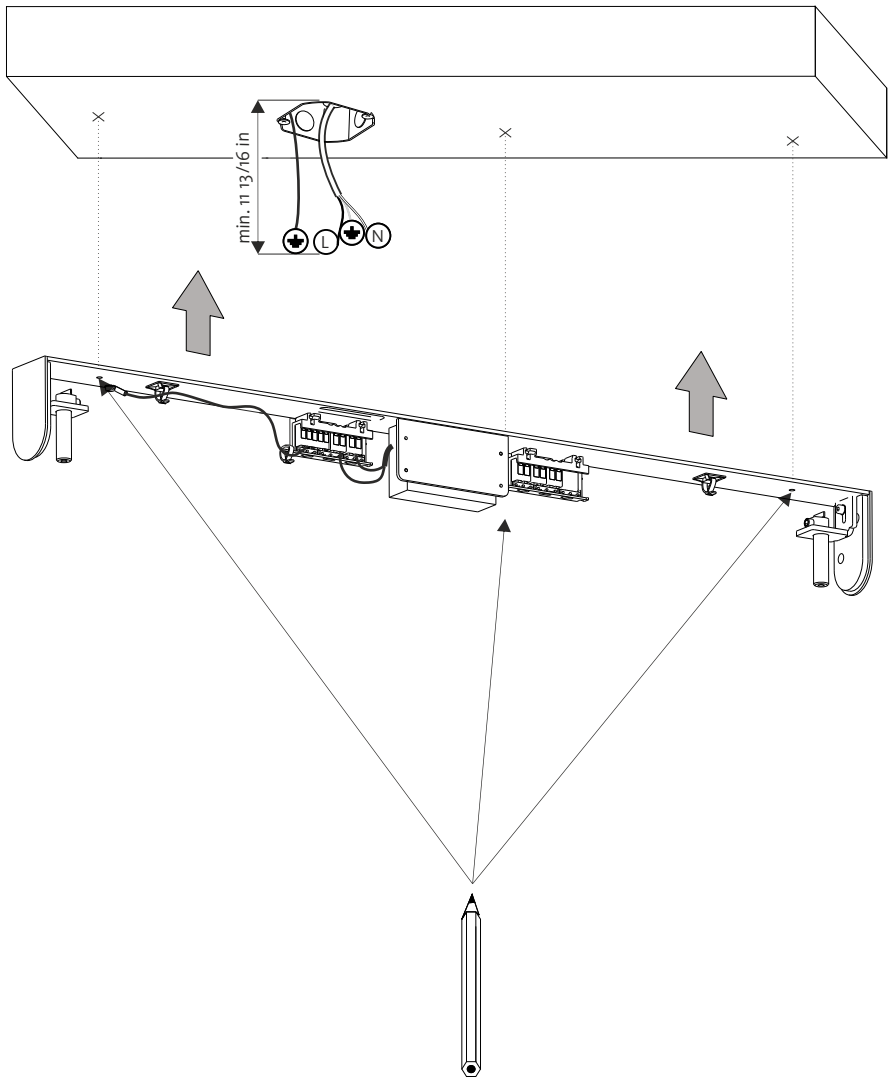

Step 6b/

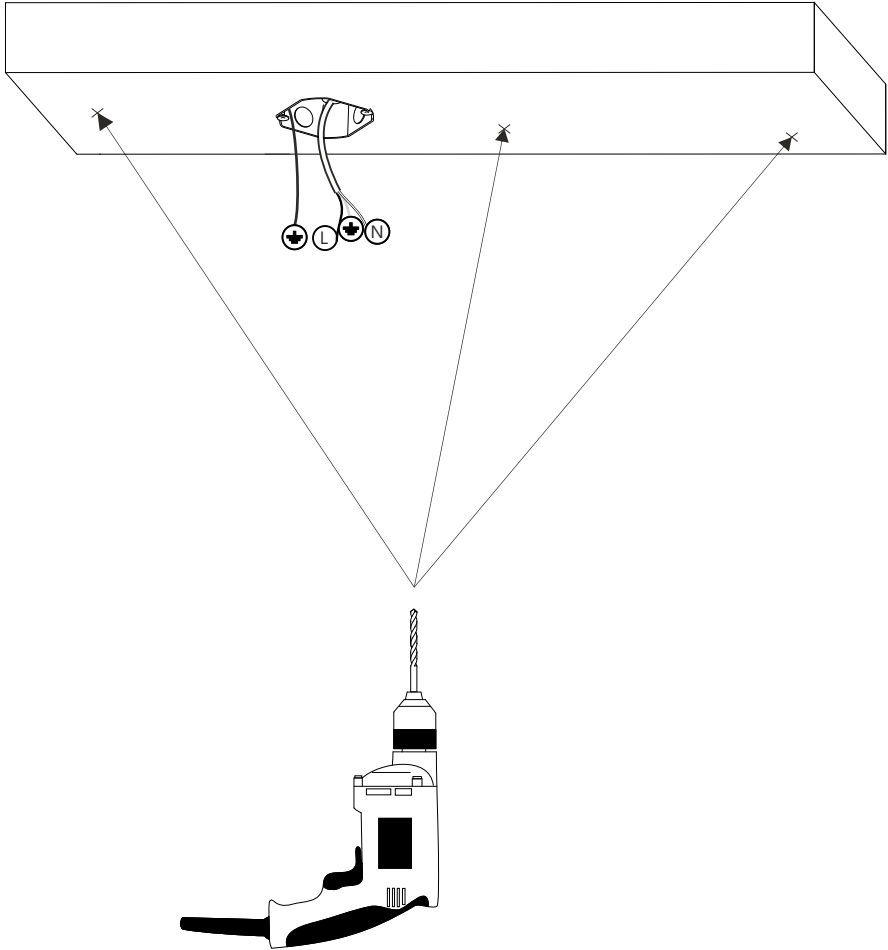

7. Fixing plate installation



Different fixing materials are needed for different ceiling structures. To reduce waste, fixing materials are not included. Consulting a specialist to select suitable fixing materials and procedures for the fixture is highly.

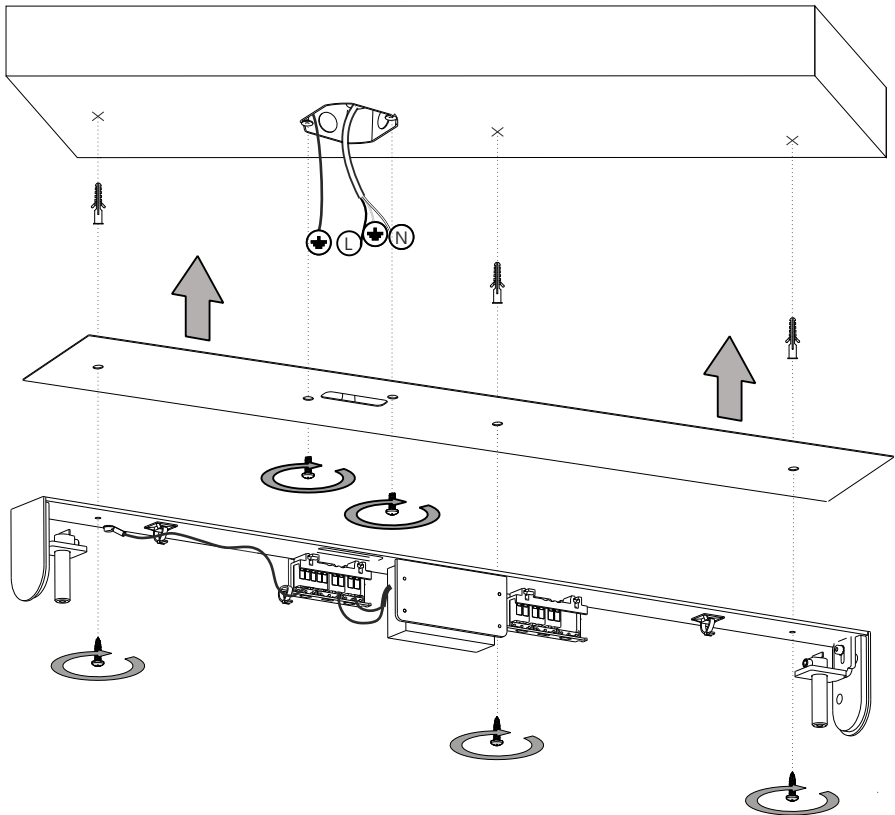

8. Cable preparation



For the required OH (x), it is necessary to mark both cables the same (y) before installing the cables to ensure the horizontality of the glass components.

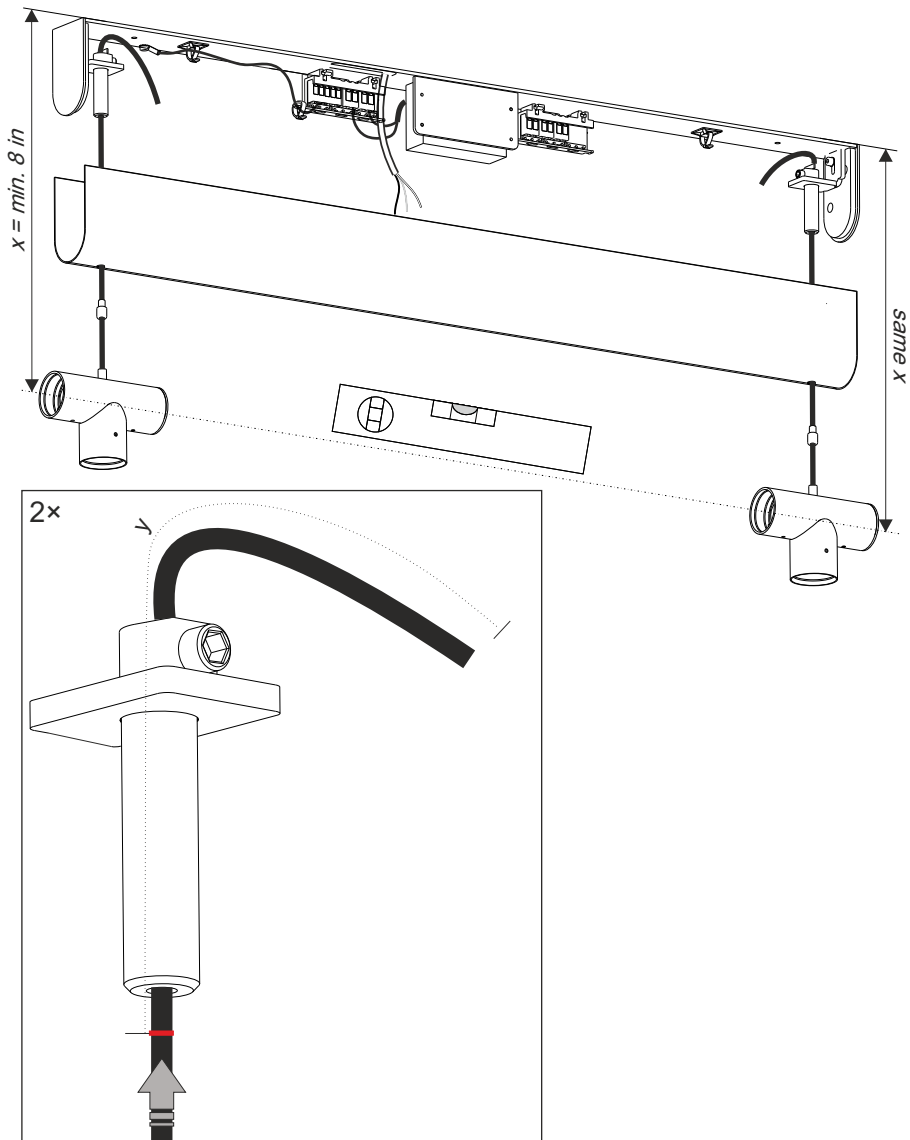

9. Electrical connection

Step 9a/ Light sources

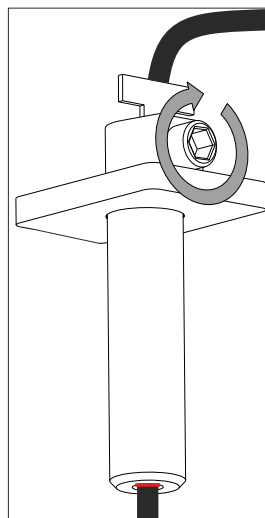
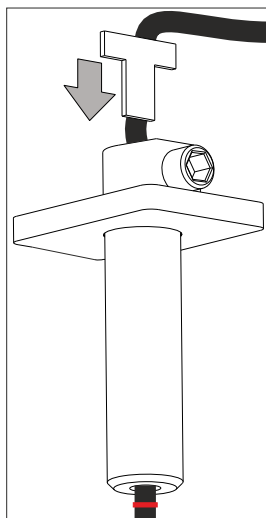
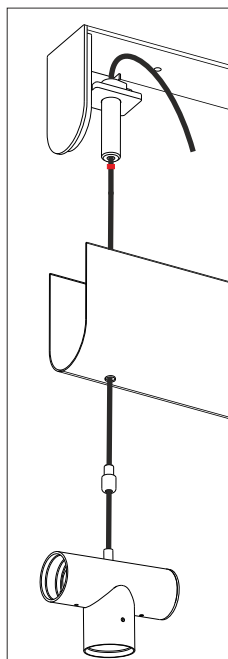
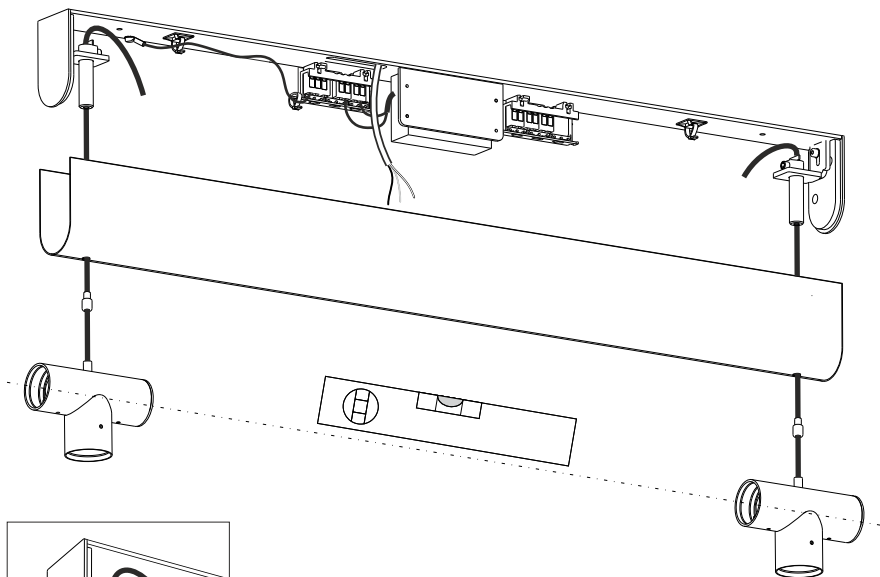

Step gb/ Main input

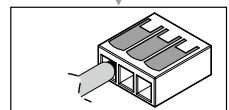
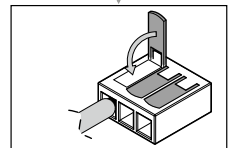
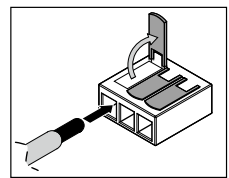
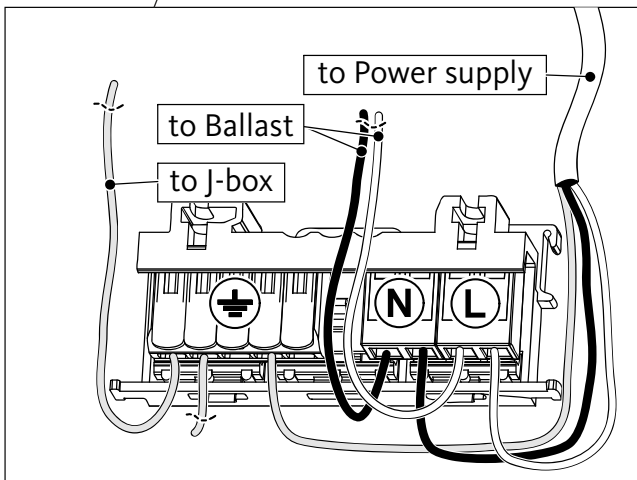
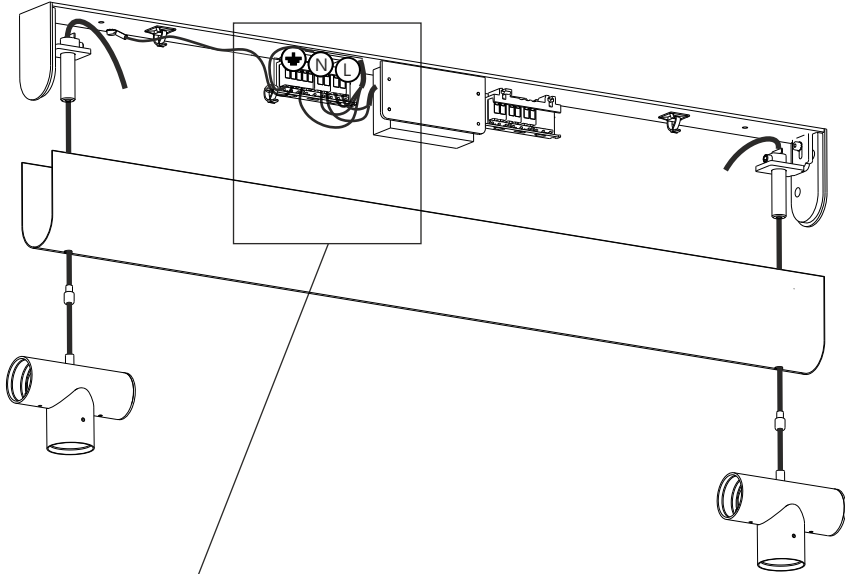

Step gc/ Light source output - all constant current LED chips are serial connected

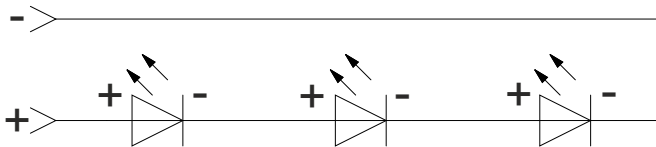
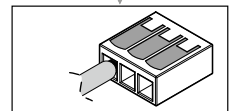
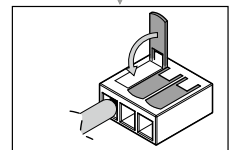
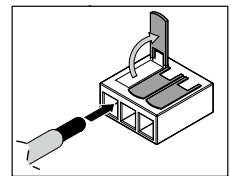
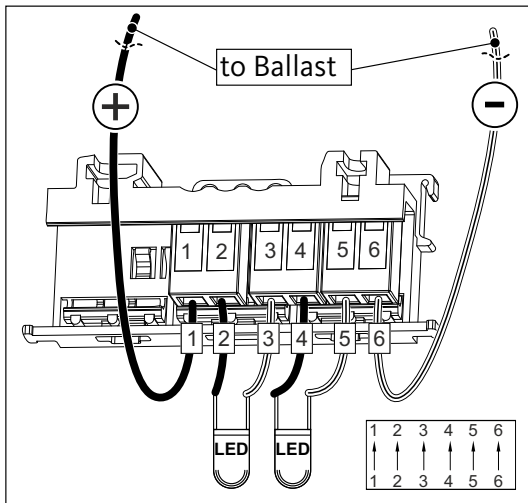
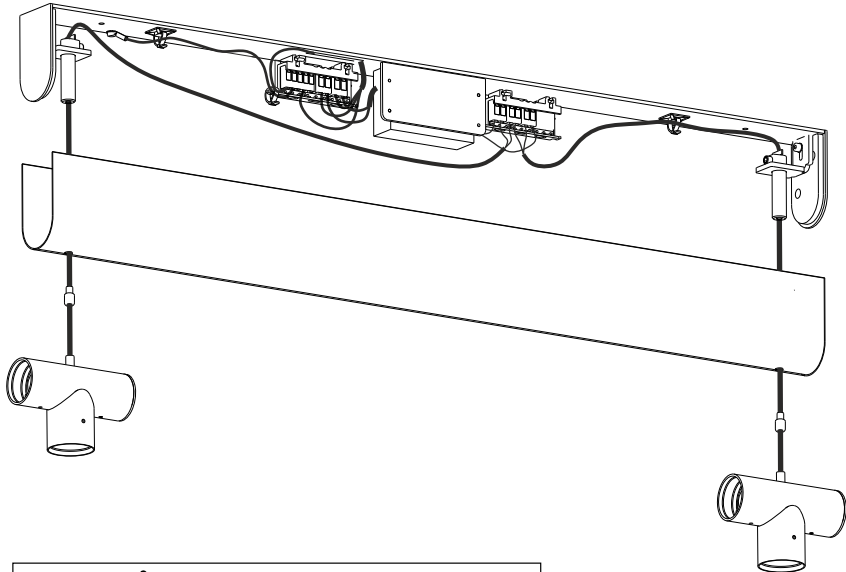

Step gd/ Canopy ground wire connection

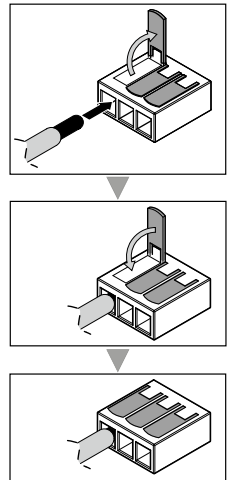
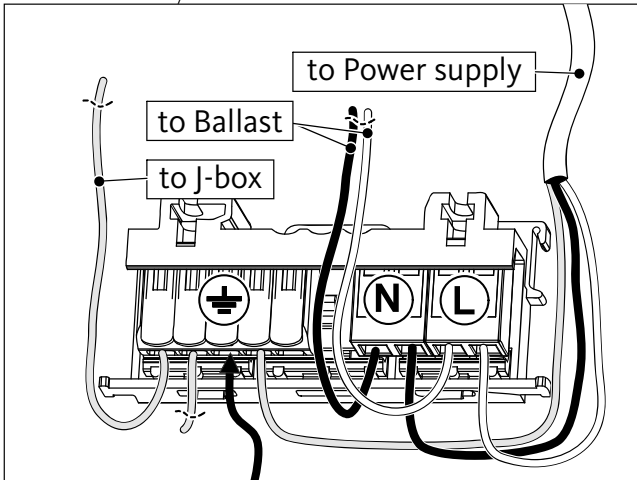
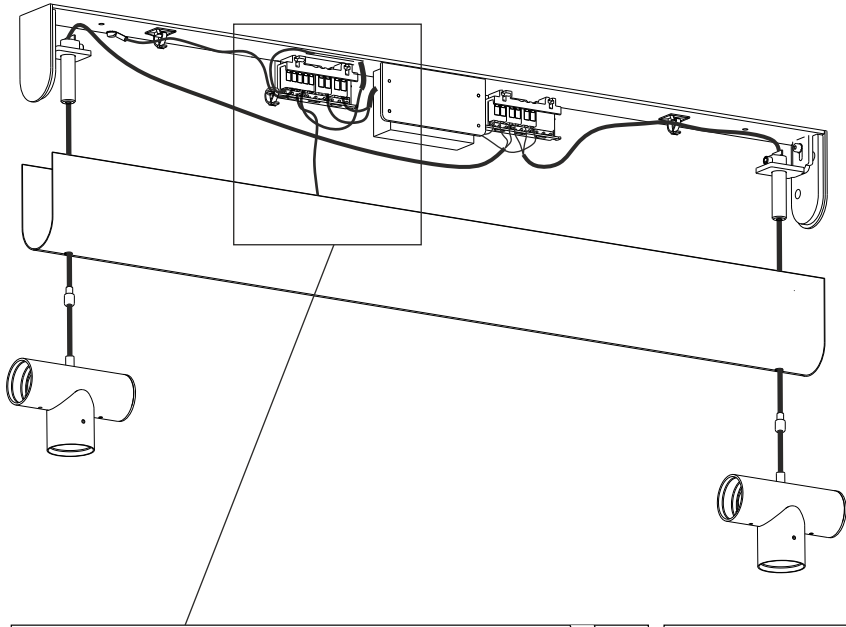

10. Canopy mounting

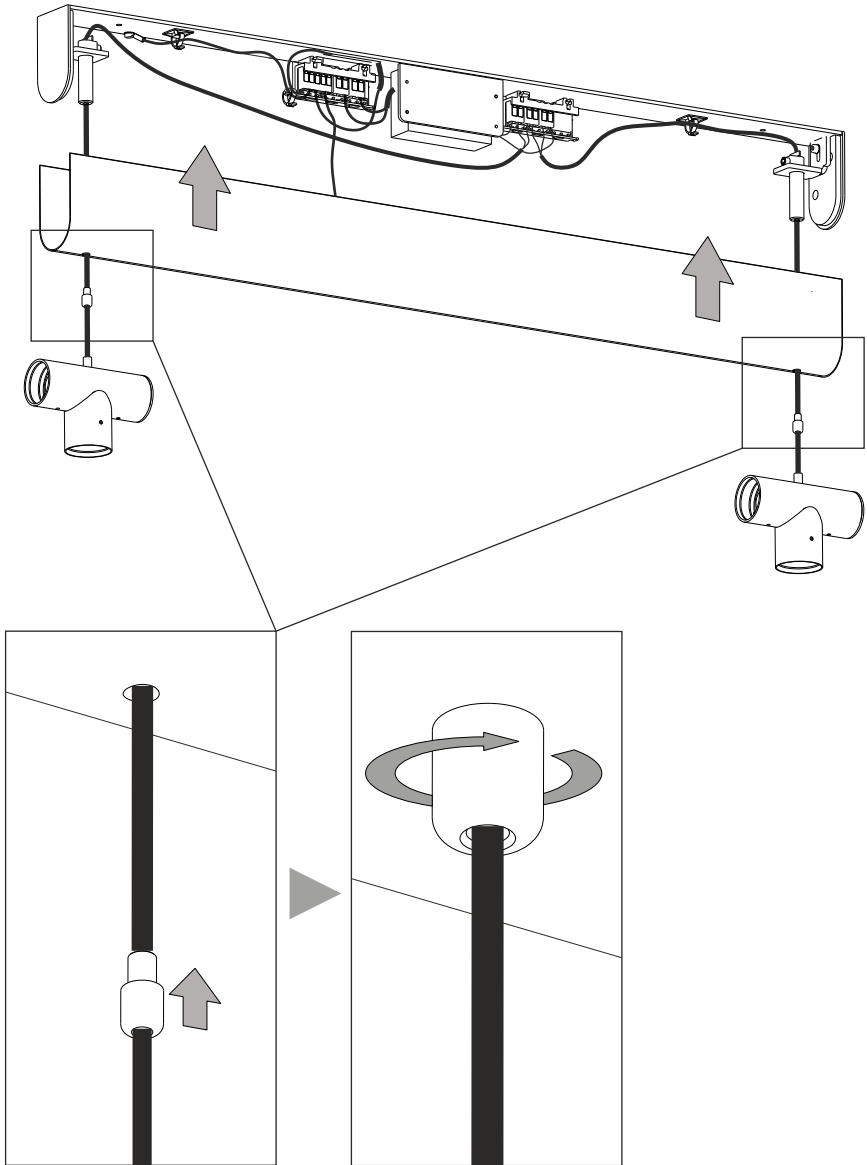

11. Installation of the glass components



Align the glass components.



Start assembling from the number 1.



Tighten the screws with care to avoid damaging the thread.

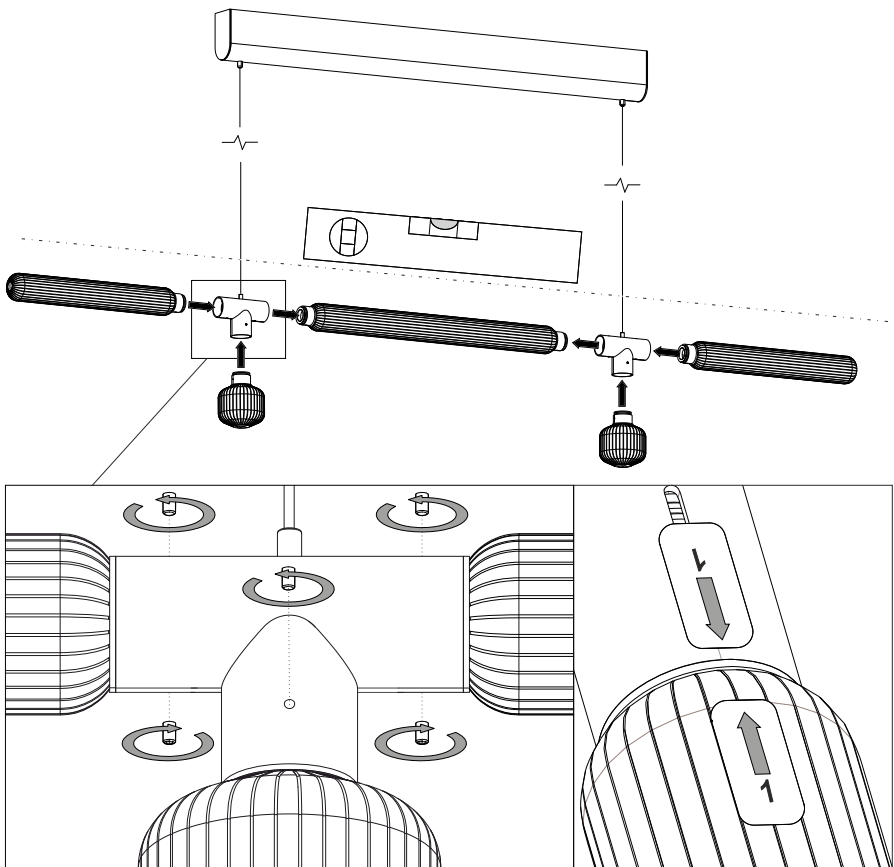

12. Warranties and Warranty Terms and Conditions

1/ The warranty is defined in the Price Quotation, Price Agreement, Contract, or Order. If the Price Quote, contract, or order is not issued, the warranty does not apply to resources, maintenance, service and cleaning. The standard warranty on the goods is set for 2 years. Other agreed warranties must be specified in the Price Quotation, Price Agreement, Contract, or Order.

2/ As a basis for the claim, the customer must provide a valid contract, invoice, or other proof of payment. Otherwise, the manufacturer reserves the right to refuse to provide a warranty, so keep the proof of product purchase carefully.

3/ If the warranty applies to the defect found, the customer informs the seller by e-mail, telephone, or the Sales department of the manufacturer (Lasvit) and passes the required information (project number or light number, project or light name and describes the defect).

4/ The Sales Department proceeds on the basis of an internal customer complaint resolution directive.

5/ The manufacturer will analyse the occurrence of a disagreement with the customer or with the manufacturer after delivery of the non-conforming product to the manufacturer's premises.

6/ Once the analysis has been made, the Sales department is handed over the decision to accept or reject the complaint with an explanation.

7/ The Sales department agrees with the customer for further steps (e.g. repair or replacement date, etc. on the basis of customer and manufacturer possibilities). Unless otherwise agreed, the manufacturer is obliged to remove the defect within 30 days of the claim date at the manufacturer's expense.

8/ The warranty does not apply to:

- warranty on bulbs
- defects caused by the customer
- defects caused by a third party
- defects caused by regular usage
- defects caused by an installation contrary to the installation manual
- defects caused by inappropriate attachment or product connection
- defects caused by performed in contradiction with the Product care manual
- defects caused by the use of other than defined light sources
- defects caused by installation in premises that do not correspond to the nature of the light and its IP cover (intrusion protection).
- defects caused by force majeure

9/ The company Lasvit has the exclusive right to grant, deny or change the terms and conditions for the provision of warranty services.



Quality Control / Passed

Controller -----

Date -----

**In case you need any assistance
or have any suggestions,
please contact us at**

lasvit.com

© LASVIT s.r.o.

Komunardů 32

170 00 Prague 7 / Czech Republic

T +420 481 120 810 / F +420 481 120 622

E customer.care@lasvit.com

LASVIT