

# LASVIT

## HIDDEN LIGHT MANUAL<sup>UL</sup>

by Jan Plecháč & Henry Wielgus



The Beauty Of Glass

EN



## Markings



### Warnings

Warns you of high risk of damage to the fixture or injury.



### Risk of electrical injury.

Warns you of high risk of injury should a live part be directly or indirectly touched.



### Notice

Warns you about possible damage to the fixture.



### Important

Important information regarding the usage of your fixture.



### Note

Gives you general information about the usage of your fixture.

---

**Please read this manual carefully and keep it in case you need assistance while performing maintenance and cleaning procedures.**



**Do not dispose of chandelier in your normal household waste. Chandelier must be wasted separately and recycled in an environmentally compatible manner.**

## General conditions



### Risk of electrical injury.

- Before starting any procedures make sure that the power to the lighting fixture is switched OFF and secured against unauthorized, negligent or accidental switching on.
- 



### Warnings

- Installation and electrical wiring should be carried out by a qualified electrician to prevent any damage to health or property.
  - This lighting fixture is to be mounted on fire proof surfaces.
  - For indoor use only! Dry location only.
  - The manufacturer shall not be held liable for any defects caused by unqualified handling of the lighting fixture.
  - Lasvit is not liable any injuries or damage to the fixture or other property caused during installation or by improper fixing.
- 



### Important

- Installation requires 2 persons.
- Fixing material is not part of the lighting fixture kit.
- Information about cleaning methods see in the Product care manual.
- Proper fixing is the responsibility of the customer.
- The light sources are replaceable by the customer.
- Light sources are provided as a reference gift.

## Step-by-step installation

1. Canopy disassembly
2. Fixing
3. Glass installation
4. Electrical wiring
5. Canopy mounting

## Other procedures

6. Light source replacement
7. Installation and warnings notes
8. Cable shortening
9. Wire shortening
10. Removing the glass for cleaning



Different fixing materials are needed for different wall/ ceiling structures. To reduce waste, fixing materials are not included. Consult a specialist to select suitable fixing materials and procedures for the fixture is highly recommended.

For illustration purposes only.

## Package contents:

**1x Glass**

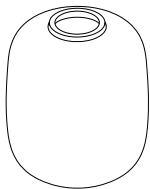

**1x Canopy**



**3x Wire**



**1x Light source assembly**

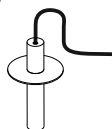

**2x Installation hooks**



**1x Allen key 2 mm**



# 1/ Canopy disassembly

Step 1a/

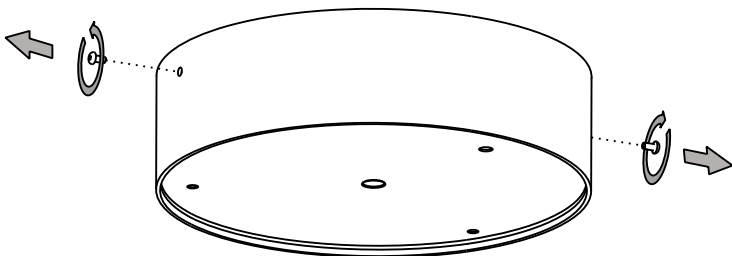

Step 1b/

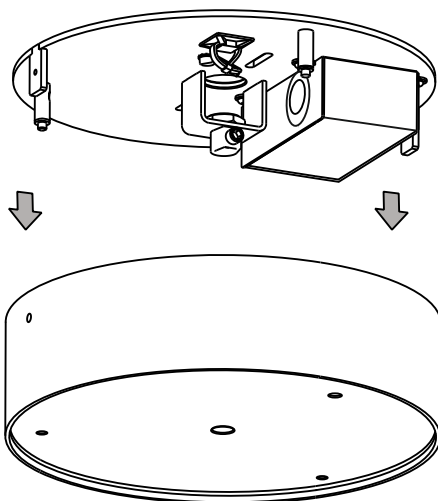

## 2/ Fixing

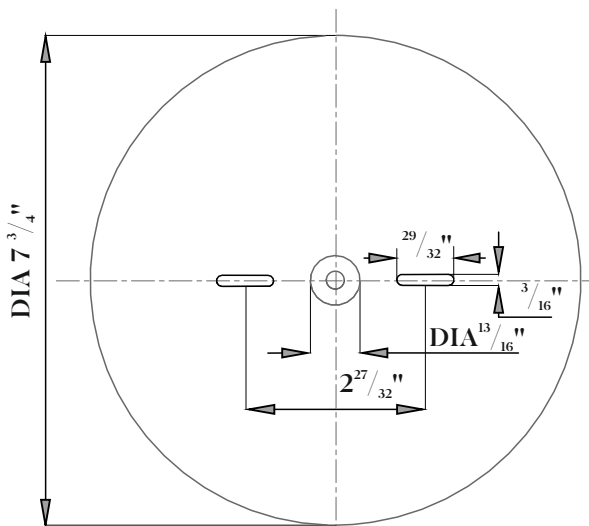

First prepare a 4" J-Box and PE cable, then you may proceed with the mount installation.

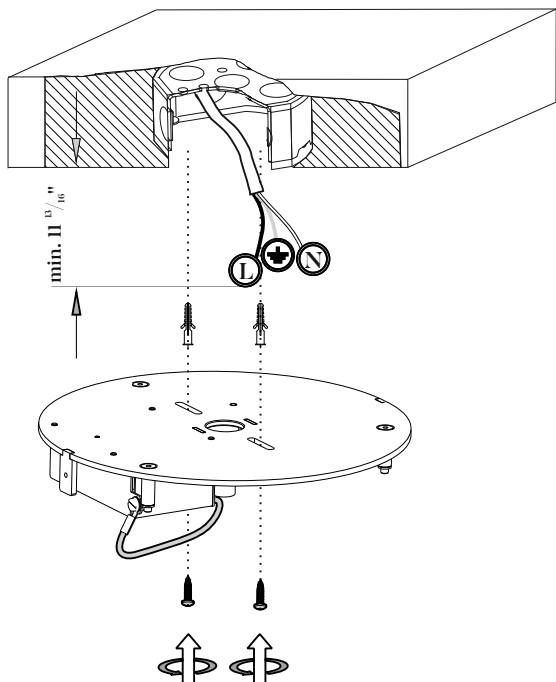



### 3/ Glass installation

Step 3a/

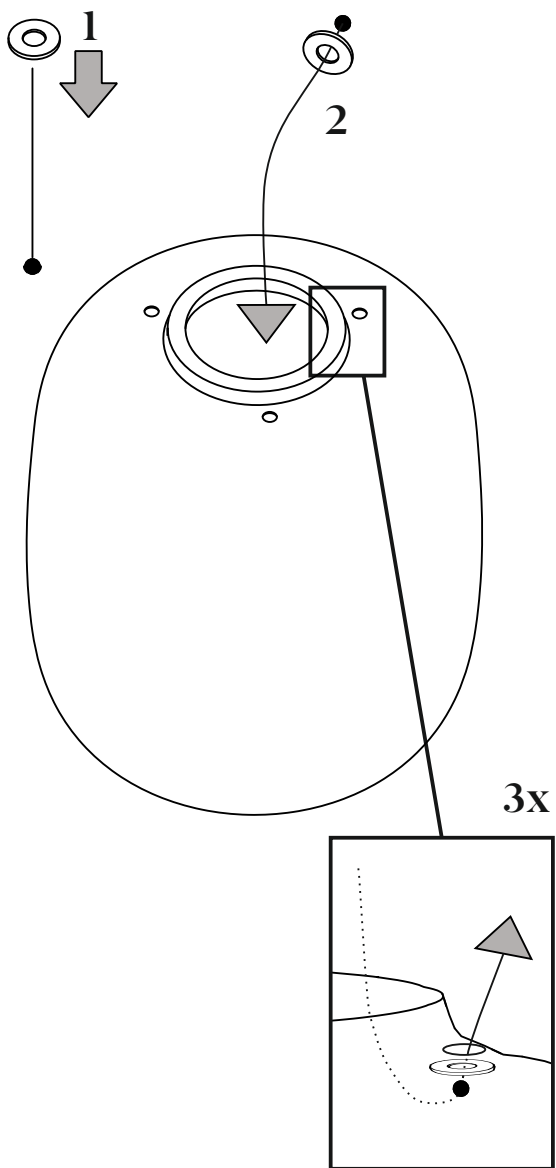

**i** For easier installation use the included installation hooks (pos. A). Take care not to break the ground cable (pos. B)

Step 3b/

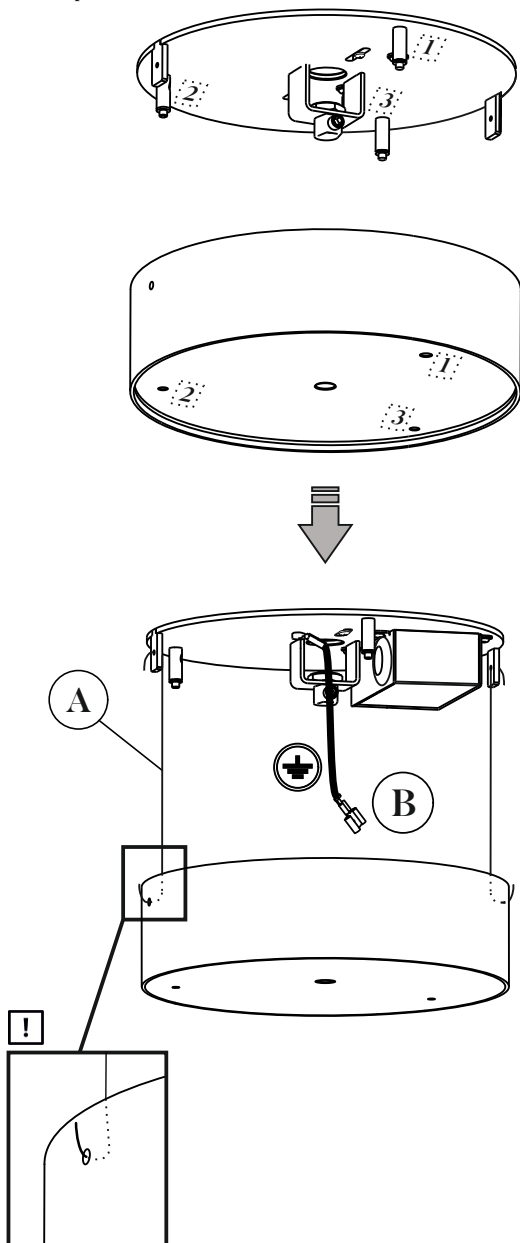

Step 3c/

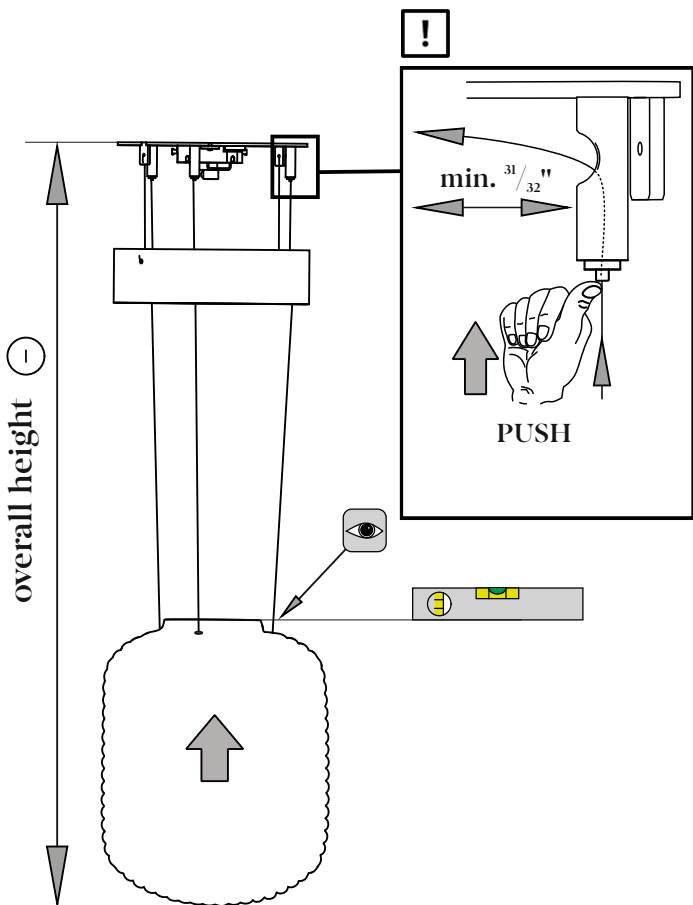

Step 3d/

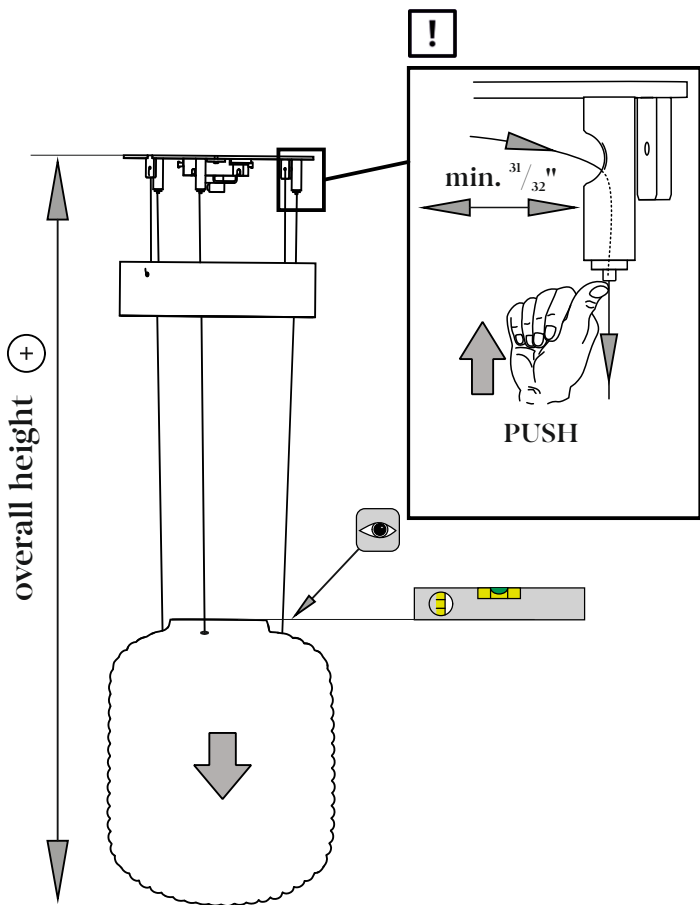

## 4/ Electrical wiring

Step 4a/

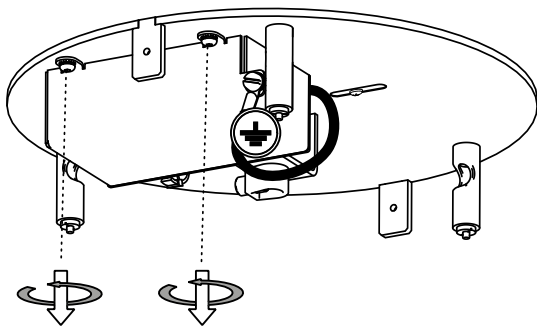

Step 4b/

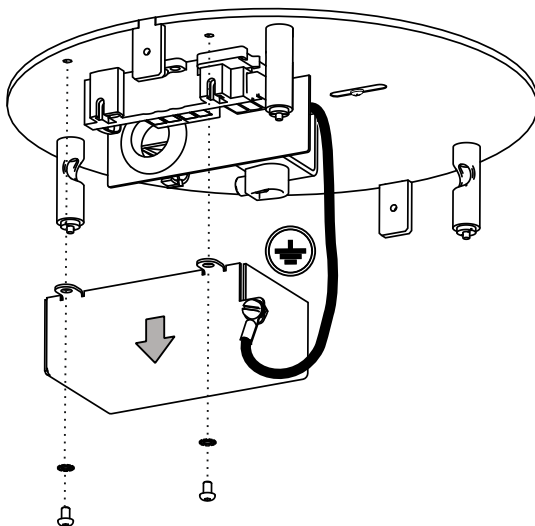

Step 4c/

Place the assembly with light source into the glass.

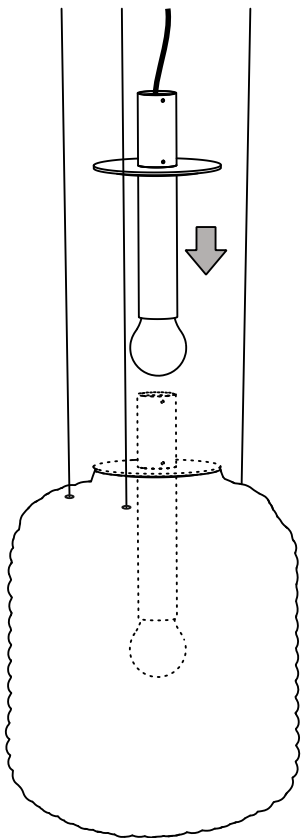

Step 4d/

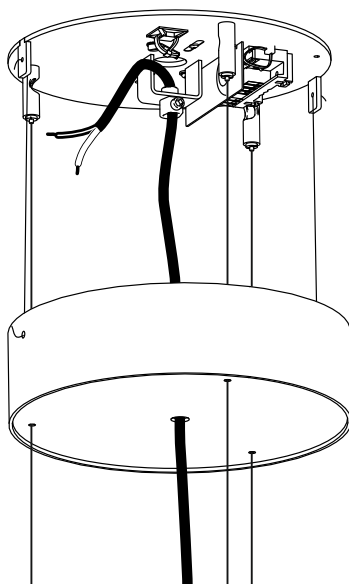
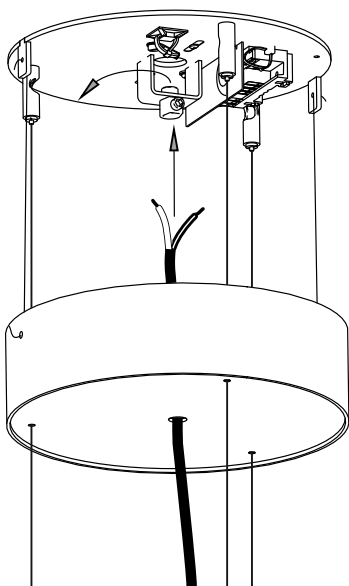

### Step 4e/ Cable layout

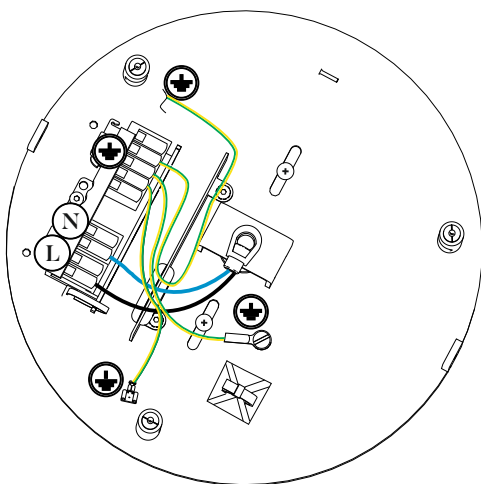
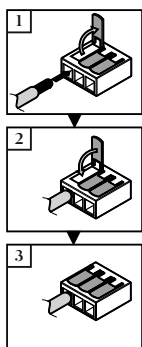

### Step 4f/

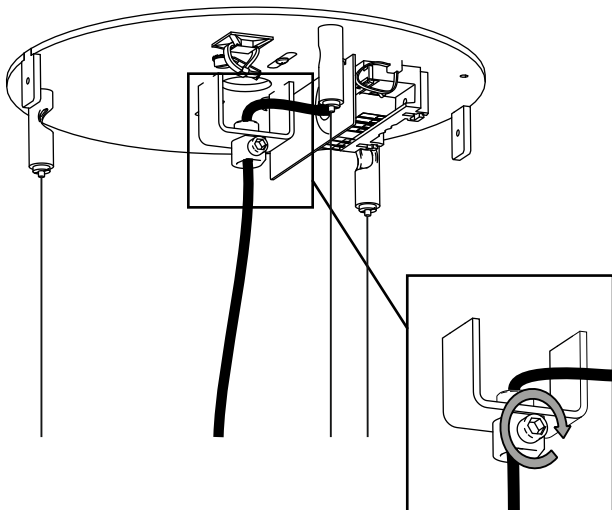



Step 4g/

### Power supply cable

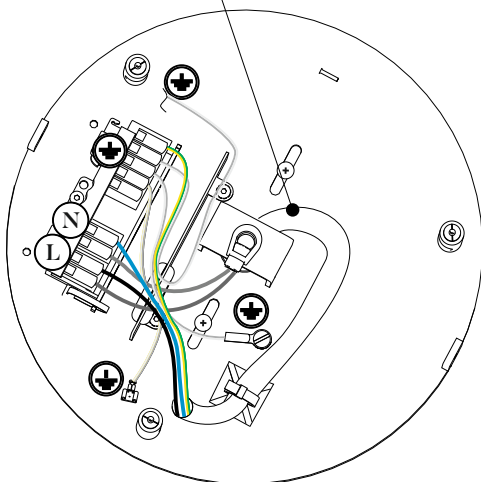
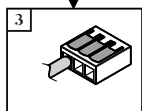
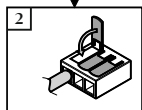
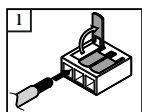

Step 4h/

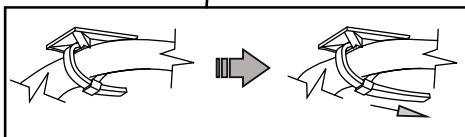
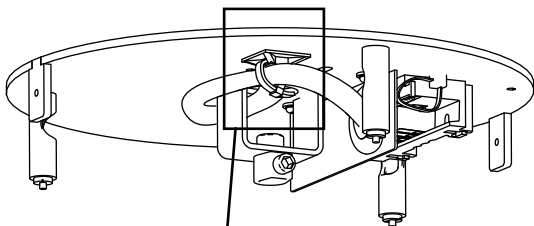

Step 4i/

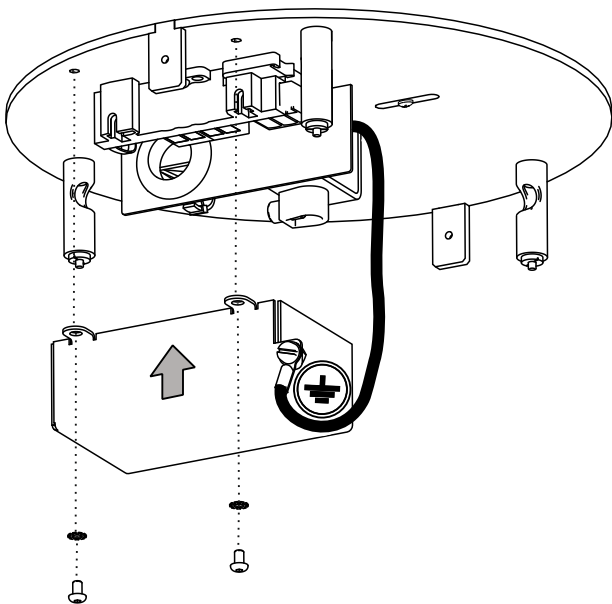

Step 4j/

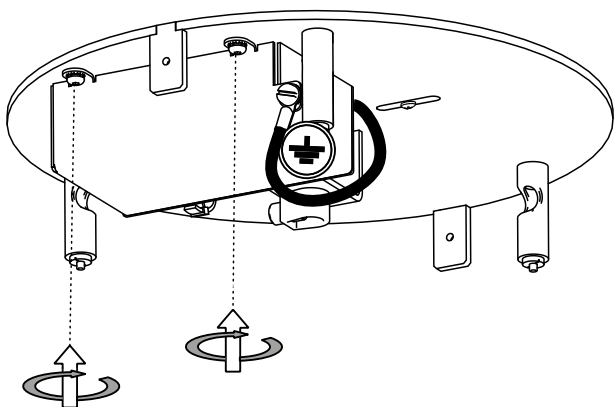

## 5/ Canopy mounting

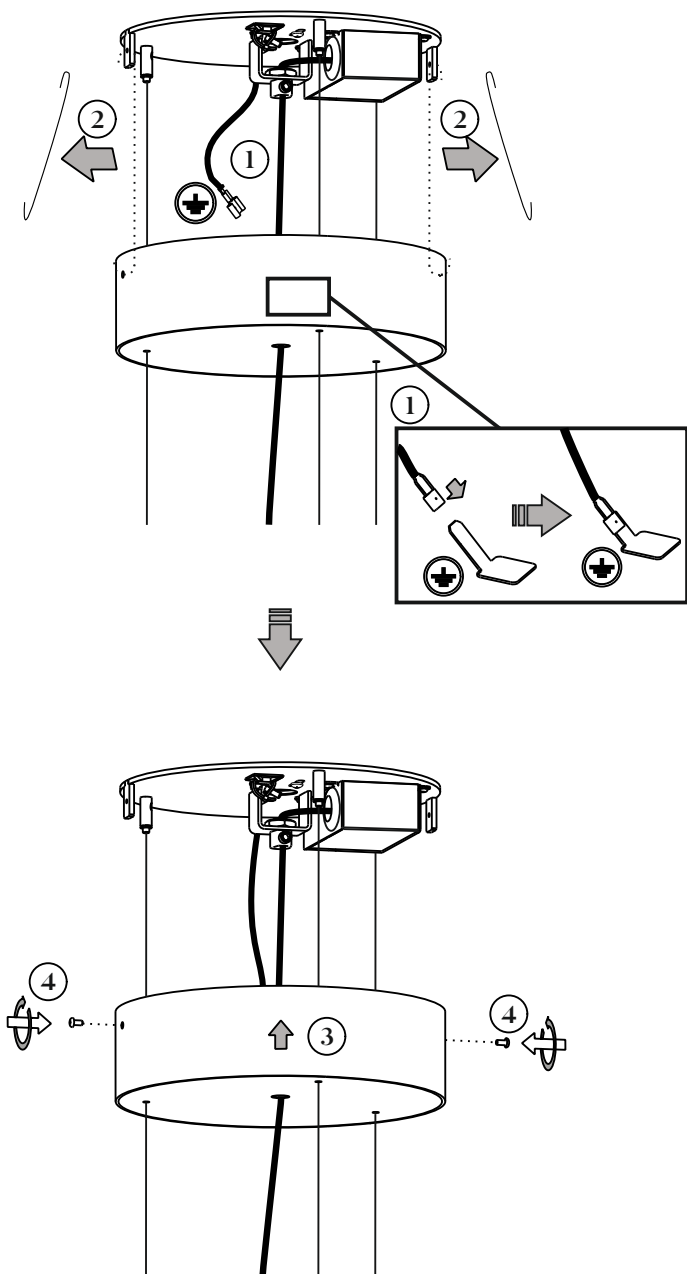

## 6/ Light source replacement

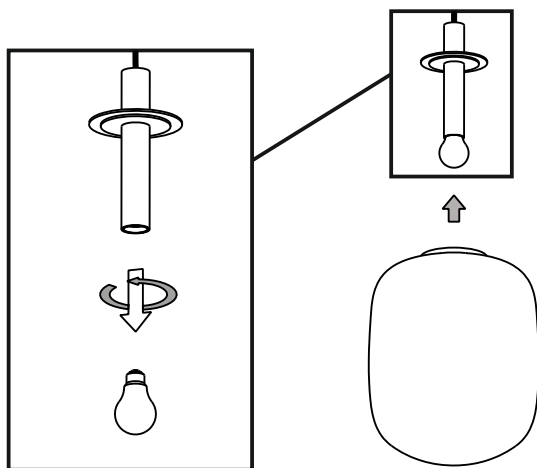

Before starting an installation make sure the power to the lighting fixture is switched OFF and secured against unauthorized, negligence or accidental switching on.



The manufacturer shall not be held responsible for injuries, damage to the fixture and / or other property when other than specified light source type and / or rating is used.



All light sources can be supplied by the manufacturer, Lasvit s.r.o. Lasvit provides NO warranty on bulbs and is not responsible for any damage or injury caused during its installation or during its operation.

## 7/ Installation and warnings notes



Should the cable need to be shortened, ask a qualified technician (licensed electrician) to disconnect the cable, shorten it and reconnect it, detailed instructions can be found in the chapter Cable shortening. Perform the cable adjustment according to valid standards.

The same applies to extend the cable, however a new, longer cable needs to be purchased separately.

Lasvit is not liable for any injuries or damage to the fixture or other property caused by unauthorized manipulation with the cable or its parts.

Do not spin the pendant! Spinning of the pendant may result in breaking of the suspension cable and / or electrical malfunction.

Do not cover the lighting fixture with any material, it is necessary for the hot parts to be cooled by freely flowing air, otherwise there is a risk of fire.

## 8/ Cable shortening



This adjustment can be carried out only by a qualified electrician.

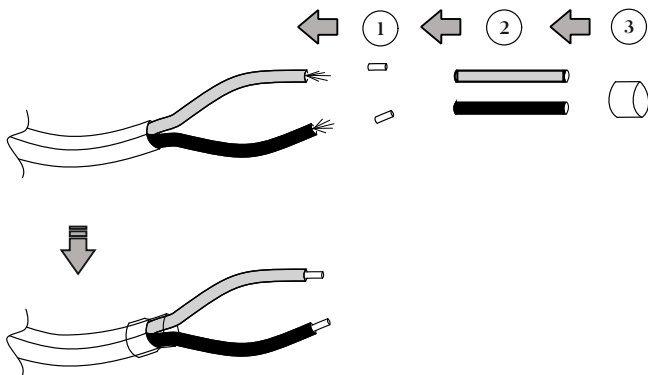

## 9/ Wire shortening



It's necessary to have minimal  $\frac{31}{32}$ " overlap of the wire (position A) above the wire gripper (position B).

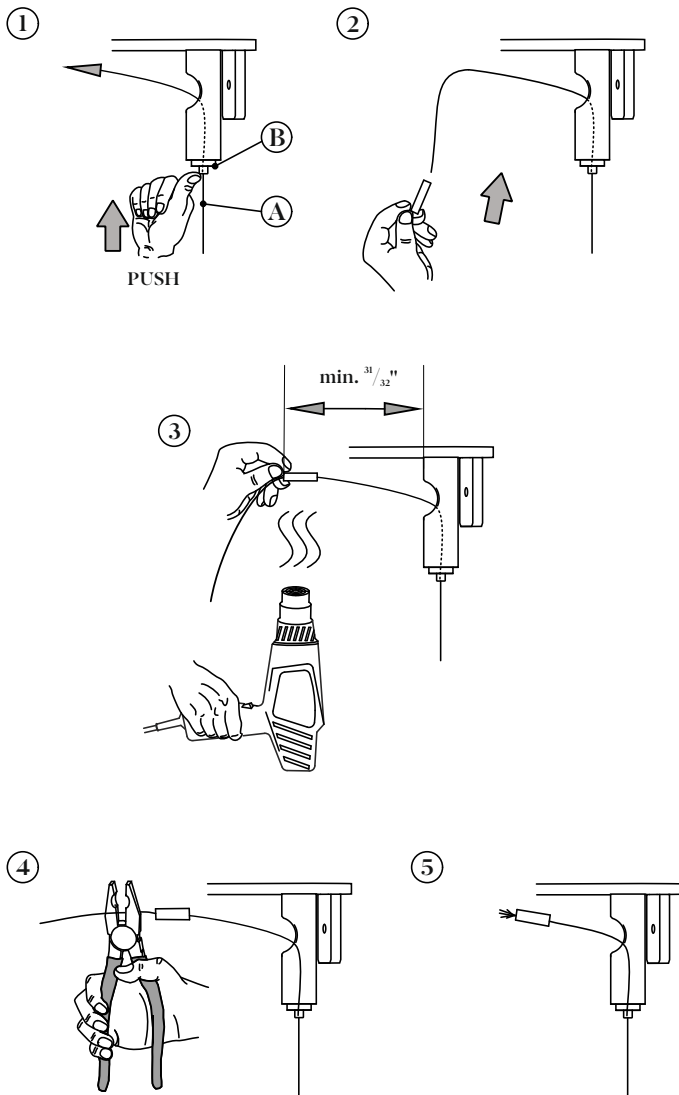

## 10/ Removing the glass for cleaning

Step 10a/

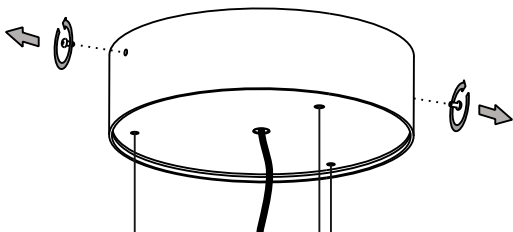

Step 10b/

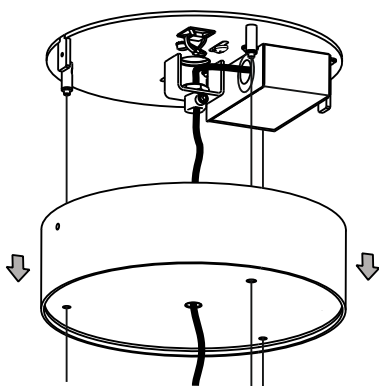

For easier installation use the included installation hooks (pos. A). Take care not to break the ground cable (pos. B)

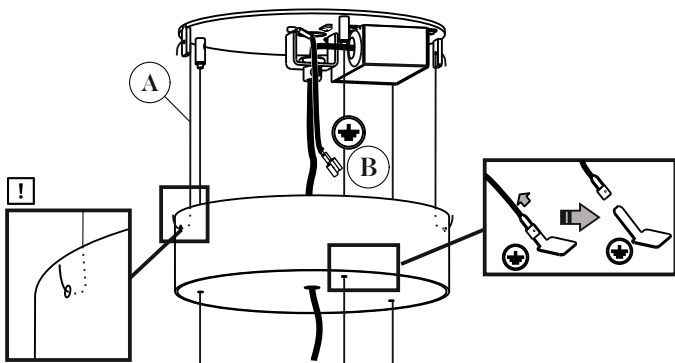

Step 10c/

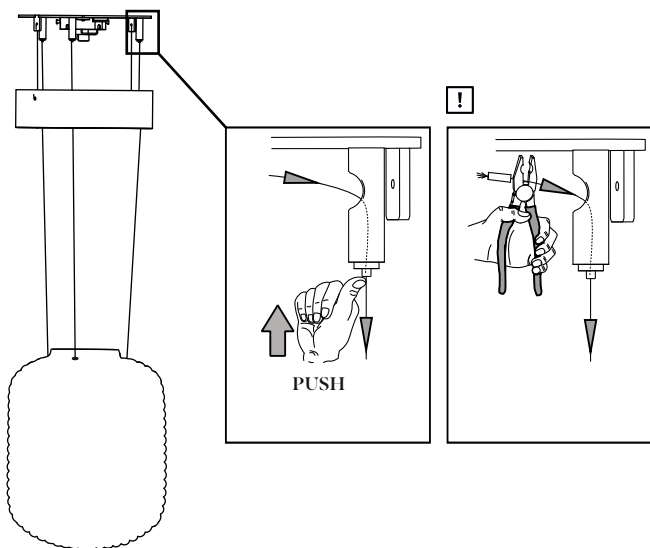

Step 10d/

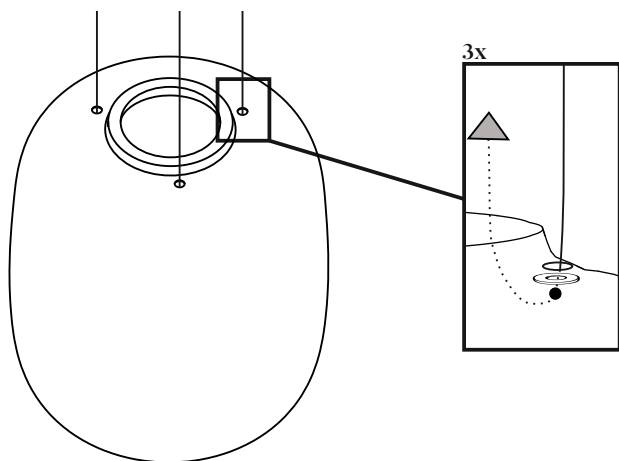

When cleaning the glass, follow the instructions in the Product care manual. When the cleaning is complete, return to the Chapter 3 (page 4) and install the glass.



# Warranties and Warranty Terms and Conditions

1/ The warranty is defined in the Price Quotation, Price Agreement, Contract, or Order. If the Price Quote, contract, or order is not issued, the warranty does not apply to resources, maintenance, service and cleaning.

The standard warranty on the goods is set for 2 years. Other agreed warranties must be specified in the Price Quotation, Price Agreement, Contract, or Order.

2/ As a basis for the claim, the customer must provide a valid contract, invoice, or other proof of payment. Otherwise, the manufacturer reserves the right to refuse to provide a warranty, so keep the proof of product purchase carefully

3/ If the warranty applies to the defect found, the customer informs the seller by e-mail, telephone, or the Sales department of the manufacturer (Lasvit) and passes the required information (project number or light number, project or light name and describes the defect).

4/ The Sales Department proceeds on the basis of an internal customer complaint resolution directive

5/ The manufacturer will analyse the occurrence of a disagreement with the customer or with the manufacturer after delivery of the non-conforming product to the manufacturer's premises.

6/ Once the analysis has been made, the Sales department is handed over the decision to accept or reject the complaint with an explanation.

7/ The Sales department agrees with the customer for further steps (e.g. repair or replacement date, etc. on the basis of customer and manufacturer possibilities). Unless otherwise agreed, the manufacturer is obliged to remove the defect within 30 days of the claim date at the manufacturer's expense.

8/ The warranty does not apply to:

- warranty on bulbs
- defects caused by the customer
- defects caused by a third party
- defects caused by regular usage
- defects caused by an installation contrary to the installation manual
- defects caused by inappropriate attachment or product connection
- defects caused by performed in contradiction with the Product care manual

- defects caused by the use of other than defined light sources
- defects caused by installation in premises that do not correspond to the nature of the light and its IP cover (intrusion protection).
- defects caused by force majeure

9/ The company LASVIT has the exclusive right to grant, deny or change the terms and conditions for the provision of warranty services.



In case you need any assistance or have any suggestion, please contact us at

[lasvit.com](http://lasvit.com)

© Lasvit s.r.o. / Komunardů 32 / 170 00 Praha 7 /  
Czech Republic T +420 481 120 810 / F +420 481 120 622 /  
E [customer.care@lasvit.com](mailto:customer.care@lasvit.com) [lasvit.com](http://lasvit.com)